

## MicroC/OS-II

## Realtime / Multitasking Operating System for Microprocessors and Microcontrollers

### General Features

- Priority based Task-Scheduling
- Preemptive Task-Scheduling
- Efficient Memory Management
- Highly Scalable
- Deterministic Execution Times
- ROMable Applications
- Large Number of Ports
- FAA Certification
- MISRA C Compliance

### Task State Diagram

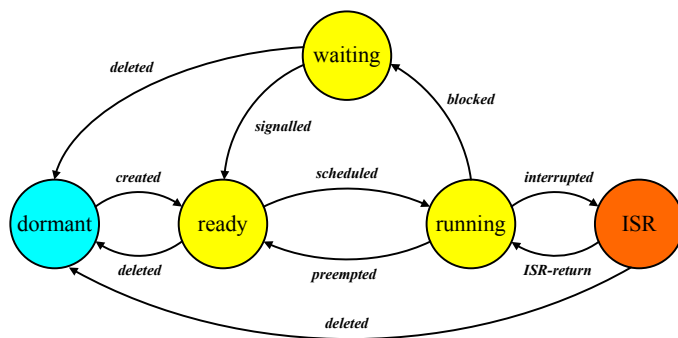

### Intertask Communication & Synchronization

### Task Management

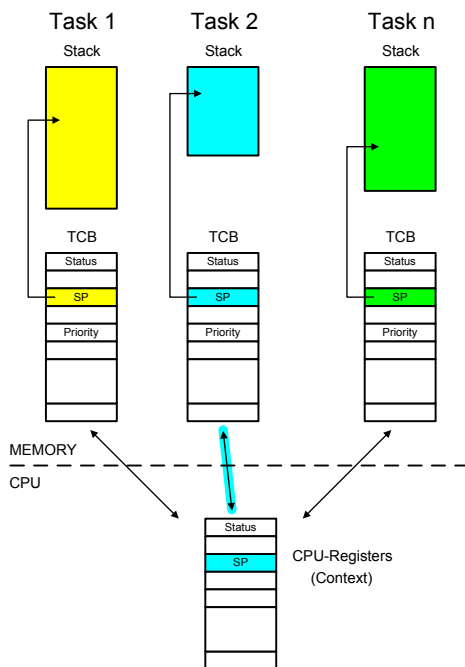

General Semaphores ■

Mutual Exclusion Semaphores ■

Mailboxes ■

Message Queues ■

Event Flags ■

### Interrupt Processing

